

YAXZ4V (TS) / NA2XBY (IEC, VDE)

Alüminyum Kablolar
Aluminum Cables

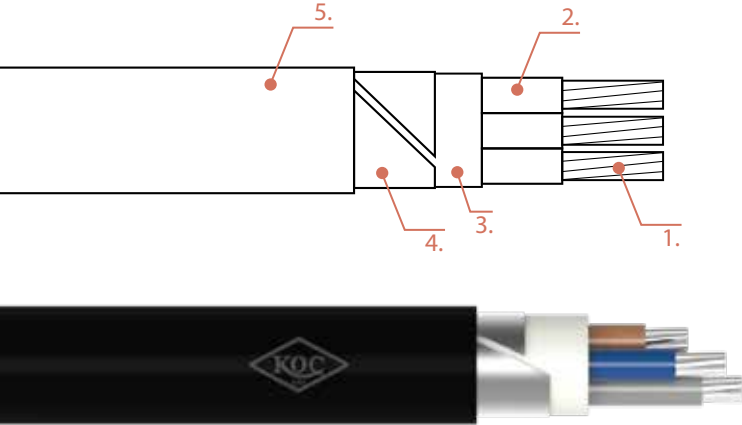

YAPISI / CONSTRUCTION

1. Çok Telli Alüminyum İletken
2. XLPE İzole
3. PVC Dolgu
4. Çift Kat Galvanizli Çelik Bant
5. PVC Dış Kılıf

1. Stranded Aluminium Conductor
2. XLPE Insulation
3. PVC Filler
4. Double Galvanized Steel Tape Armour
5. PVC Outer Sheath

Standartlar: TS IEC 60502-1

TEKNİK BİLGİLER

Max. Çalışma Sıcaklığı:	90°C
Min. Bükülme Yarıçapı:	15xD
Anma Gerilimi:	0.6/1 kV
Max. Kısa Devre Sıcaklığı:	250°C
Test Voltajı:	3,5 kV

TECHNICAL DATA

Max. Operating Temp:	90°C
Min. Bending Radius:	15xD
Rated Voltage:	0.6/1 kV
Max. Short Circuit Temp:	250°C
Test Voltage:	3,5 kV



KULLANIM YERLERİ / APPLICATIONS

- NA2XBY, enerji santralleri, endüstriyel tesisler, şalt sahaları ve dış mekan enerji dağıtımı gibi uygulamalar için ideal olup, güvenilir ve uzun ömürlü performansı ile tercih edilmektedir. Bu kablo ayrıca, alev geciktirici özellikleri ve yüksek sıcaklık kapasitesi ile güvenlik standartlarına uyumlu bir enerji çözümü sunar. UV direnci dış mekan uygulamaları için de kullanımına izin verirken, bu kabloların su içinde kullanım için uygun olmadığını belirtmek gerekir.
- NA2XBY is ideal for applications such as power plants, industrial facilities, switchyards and outdoor energy distribution and is preferred for its reliable and long-lasting performance. This cable also offers an energy solution that complies with safety standards with its flame retardant properties and high temperature capacity. While UV resistance also allows its use for outdoor applications, it is worth noting that these cables are not suitable for use in water.

YAXZ4V (TS) / NA2XBY (IEC,VDE)



XLPE İzoleli, Pvc Kılıflı, Çelik Bantlı, Alüminyum İletkenli Yer Altı Kabloları

XLPE Insulated, Pvc Sheathed, Galvanized Steel Tape Underground Cable With Aluminium Conductor



Nominal Kesit (mm ²)	Dış Çap (mm) Yaklaşık	Net Ağırlık (kg/km) Yaklaşık	Standart Sevki Uzunluğu (m)	20°C'de İletken DC Direnci (ohm/km)	Akım Taşıma Kapasitesi	
					Toprakta (A)	Havada (A)
Nominal Cross Section (mm ²)	Overall Diameter (mm) Approx	Net Weight (kg/km) Approx	Standard Delivery Length (m)	Conductor DC Resistance at 20°C (ohm/km)	Current Carrying Capacity In	
					Ground (A)	Air (A)

YAXZ4V (TS) / NA2XBY (IEC,VDE)

Nominal Cross Section (mm ²)	Overall Diameter (mm) Approx	Net Weight (kg/km) Approx	Standard Delivery Length (m)	Conductor DC Resistance at 20°C (ohm/km)	Ground (A)	Air (A)
3x25	26,0	1250	1000	1,2000	62	78
3x35	28,6	1500	500	0,8680	77	96
3x50	33,0	1900	500	0,6410	92	117
3x70	37,0	2350	500	0,4430	116	150
3x95	42,0	2950	500	0,3200	139	183
3x120	45,5	3500	500	0,2530	160	212
3x150	50,0	4200	500	0,2060	176	245
3x185	55,0	5000	500	0,1640	199	280
3x240	61,5	6200	500	0,1250	232	330
3x300	68,0	7450	500	0,1000	265	381
3x25+16	27,5	1500	1000	1,20 1,91	62	78
3x35+16	29,5	1550	1000	0,868 1,91	77	96
3x50+25	34,0	2050	500	0,641 1,20	92	117
3x70+35	38,5	2550	500	0,443 0,868	116	150
3x95+50	43,0	3250	500	0,320 0,641	139	183
3x120+70	48,0	3900	500	0,253 0,443	160	212
3x150+70	52,0	4500	500	0,206 0,443	176	245
3x185+95	57,0	5400	500	0,164 0,320	199	280
3x240+120	63,5	6650	500	0,125 0,253	232	330
3x300+150	70,0	8000	500	0,100 0,206	265	381

YAXZ4V (TS) / NA2XBY (IEC,VDE)



Nominal Kesit (mm ²)	Dış Çap (mm) Yaklaşık	Net Ağırlık (kg/km) Yaklaşık	Standart Sevk Uzunluğu (m)	20°C'de İletken DC Direnci (ohm/km)	Akım Taşıma Kapasitesi	
					Toprakta (A)	Havada (A)
Nominal Cross Section (mm ²)	Overall Diameter (mm) Approx	Net Weight (kg/km) Approx	Standard Delivery Length (m)	Conductor DC Resistance at 20°C (ohm/km)	Current Carrying Capacity In	
					Ground (A)	Air (A)

YAXZ4V (TS) / NA2XBY (IEC,VDE)

4x25	28,5	1500	1000	1,2000	62	78
4x35	31,0	1750	1000	0,8680	77	96
4x50	36,5	2300	500	0,6410	92	117
4x70	40,5	2850	500	0,4430	116	150
4x95	46,0	3550	500	0,3200	139	183
4x120	50,0	4250	500	0,2530	160	212
4x150	55,5	5100	500	0,2060	176	245
4x185	61,0	6100	500	0,1640	199	280
4x240	38,0	7550	500	0,1250	232	330
4x300	75,0	9100	500	0,1000	265	381